



The crawler Häggloaders are electro-hydraulic driven, trackless loaders with a back-hoe digging system.

Technical features

- Hydraulic system powered by electric engine.
- The electro-hydraulic drive provides low installation and energy costs, and maintains good air quality.
- The back-hoe digging system loads the muck onto the conveyor, which then fills the haulage vehicle or Shuttlecar with a constant flow of muck.
- The dozer blades clean the sole effectively thus eliminating the need of manual clean up.
- The back-hoe system can be used for lifting and scaling and can be repaired with standard sheet metal.
- The conveyor can be raised and lowered to suit the loading height of different haulage vehicles.
- Significantly reduces the number of niches needed.
- A built in sprinkler system controls dust effectively.
- Suitable for use in drifts and tunnel with cross section from 10 m² and upwards.
- The Häggloader is operated from a standing position in a compartment with height adjustable roof.
- The drivers compartment is equipped with backrest and arm rests beside the operating equipment.
- The Häggloader is controlled by hydraulic joysticks.
- The chassis and conveyor are made of heavy duty plate joined together with continuous welds for maximum fatigue strength.
- The service brake is hydraulic. The Häggloader also has a spring applied hydraulic released parking and emergency brake.

Standard

CE mark according to European standards.

Options

- *Cable reel*
Length and dimension of cable depends on the voltage chosen. Capacity 100 m at 400V.
- *Pony track for towing on rail.*
- *Hydraulic hammer SB152*

Other options and dimensions on request.

Technical data

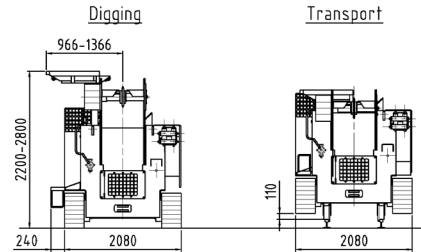
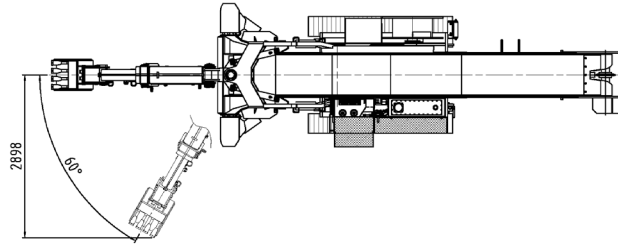
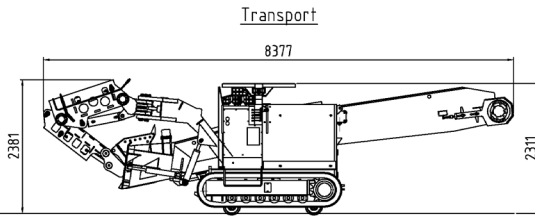
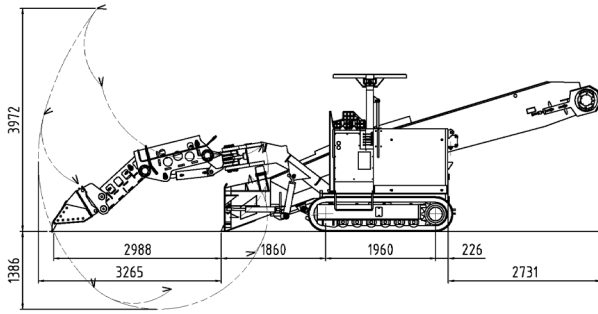

Standard electric system

Electrical motor	73 kW
Voltage	400-690 V
Lamps	6 x 70 W

Transmission

Maximum travel speed

Electric	1,5 km/h
Towing speed (pony track)	maximum 15 km/h

Volume data-service

Hydraulic tank incl. cooler	300 dm ³
-----------------------------	---------------------

Dimensions during transport

Total length	8 377 mm
Width	2 080 mm
Total height	2 200 mm
Ground clearance	110 mm
Pony track gauge	600, 750, 900 mm
Weight	11 500 kg

Functional data

Ground clearance	180 mm
Digging depth below ground level	1 380 mm
Bending force at the bucket tip	5 000 kp
Tractive pull	10 500 kp
Steering	Skid
Brakes	Hydraulic / SAHR
Max work gradient (uphill)	1:5 (20%)
Max work gradient (downhill)	1:7 (14%)
Loading capacity	approx. 3-4 m ³ /min
Digging width	max 5 800 mm
Dozer blades	3 100, 2 550, 3 800 mm
Crawlers	Caterpillars
Wheel base	1 980 mm
Track width	1 730 mm

Contact us for further information.

GIA Industri AB
Box 59
SE-772 22 Grängesberg
Sweden

Phone +46 (0)240 797 00
Fax +46 (0)240 797 25
Email: info@gia.se
Web: www.gia.se

Häggloader 9HR-B