

The wheel borne Häggloaders are rubber tyred electro-hydraulic driven, trackless loaders with a back-hoe digging system. Available in two models 7HR-B and 10HR-B.

Technical features

- Hydraulic system powered by electric or diesel engine.
- The electro-hydraulic drive provides low installation and energy costs, and maintains good air quality.
- The diesel-hydraulic drive is used for transportation and can also be used for minor digging work.
- The back-hoe digging system loads the muck onto the conveyor, which then fills the haulage vehicle with a constant flow of muck.
- The dozer blades clean the sole effectively thus eliminating the need of manual clean up.
- The back-hoe system can be used for lifting and can be repaired with standard sheet metal.
- The conveyor can be raised and lowered to suit the loading height of different haulage vehicles.
- Significantly reduces the number of niches needed and reduces tyre wear.
- A built in sprinkler system controls dust effectively.
- Suitable for use in drifts and tunnel with cross section from 7 m² and upwards.
- The driver operates from a compartment with protection roof, a gate and a comfortable backrest.
- The Häggloader is controlled by PLC via a LCD-panel and joysticks.
- The chassis and conveyor are made of heavy duty plate joined together with continuous welds for maximum fatigue strength.
- The front and rear axle steering provides excellent agility and the ability to travel sideways in confined spaces.
- The service brake is hydraulic. The Häggloader also has a spring applied hydraulic released parking and emergency brake.

Standard

CE mark according to European standards.

Options

- *Extended conveyor*
- *Dual digging arm system*
- *Coupling device*
- *Hydraulic hammer SB152*
- *Cable reel*
Length and dimension of cable depends on the voltage chosen. Capacity 100 m at 400V.

Other options and dimensions on request.

Technical data

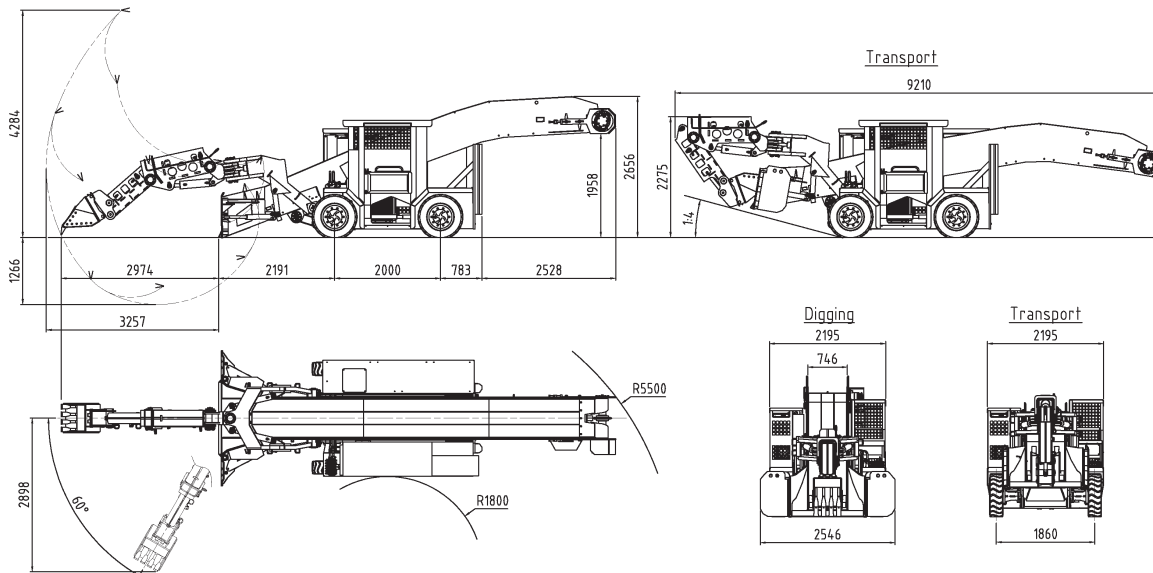

Engine

Deutz diesel engine (stage III) including silencer and catalytic purifier. Diesel engine for transport and minor loading.

Type: BF4L2011, 58 kW @ 2 800 rpm

Standard electric system

Electrical motor	45 kW
Voltage	400-690 V
	1 000 V
Battery capacity	2 x 12 V - 70 Ah
Generator capacity	40 A
Lamps	8 x 35 W HID

Transmission

Maximum travel speed

Electric	3 km/h
Diesel	10 km/h

Volume data-service

Engine oil volume	11 dm ³
Fuel tank	96 dm ³
Hydraulic tank incl. cooler	250 dm ³

Dimensions during transport

Total length	9 210 mm
Width	2 195 mm
Total height	2 275 mm
Weight	13 000 kg

Functional data

Ground clearance (frame)	150 mm
Digging depth below ground level	1 266 mm
Tractive pull (4 wheel drive)	7 200 kp
Steering	4 wheel
Max work gradient (uphill)	1:5 (20%)
Max work gradient (downhill)	1:7 (14%)
Loading capacity	approx. 1,5 m ³ /min
Digging width	5 700 mm
Dozer blades	2 550, 3 100 mm
Tyres	8.25x15"
Wheel base	2 000 mm
Track width	1 860 mm

Contact us for further information.

GIA Industri AB
Box 59
SE-772 22 Grängesberg
Sweden

Phone +46 (0)240 797 00
Fax +46 (0)240 797 25
Email: info@gia.se
Web: www.gia.se

Häggloader 7HR-B